

**Innovative technologies facilitate
a future of sustainable energy
resource development**

Responsible, efficient exploration and production of energy has become a highly technical undertaking. Innovative technical services offer an unparalleled opportunity to improve that process, thereby reducing environmental impact, increasing safety and improving producers' speed and profitability.

Since its founding in 1999 WellDog has built a reputation for adapting cutting-edge technology to create practical, easy-to-adopt technical solutions for key resource evaluation and production challenges.

WellDog is an energy-focused technical services company that developed its own patented, proven Reservoir Raman chemical sensing systems to provide commercial reservoir analysis services for coal, gas, alternative and conventional resources.

Building on the strength of those services and the company's worldwide customer focus, WellDog now develops, sources, advances and manages a diverse set of innovative technical solutions. The company focuses on platform technologies that enable solutions to address the critical needs of today's unconventional and alternative energy industries in a high volume, low cost manner.

Visit us at www.welldog.com or call us and step into the future of energy resource development.



Company Headquarters
1482 Commerce Drive, Suite A
Laramie, Wyoming, USA 82070
Tel: +1-307-742-6340
Fax: +1-307-742-6342

Asia Pacific Regional Headquarters
Suite 2303, Level 23, 127 Creek St
Brisbane, 4000, Queensland, Australia
Tel: +61 7 3218 2175
Fax: +61 7 3839 4649

www.welldog.com

© 2011 Gas Sensing Technology Corp. (GSTC) and WellDog Pty Ltd.
"WellDog" is a registered trademark of GSTC used under license to WellDog Pty Ltd. "Truly Unconventional" and the WellDog logo are trademarks of GSTC used under license to WellDog Pty Ltd.



Truly Unconventional

**WellDog's award-winning technical services
accelerate responsible development of unconventional,
alternative and conventional energy resources**

Sustainable Practices — Sustainable Industry

WellDog's technical services focus on reducing environmental impacts without reducing resource development:

- Reducing greenhouse gas emissions
- Preserving water resources for future generations
- Maximizing society's access to clean energy resources

Your Problem is Our Problem

When you hire WellDog, we join your team and tackle your challenges head-on. Our team of engineers, scientists, and operations experts have decades of experience in solving complex problems and analyzing situations using sparse data sets.

We have built an international reputation for:

- Accelerating asset monetization
- Reducing scale of development while increasing resource production volumes
- Using technical best practices to optimize exploration and production
- Focusing on the challenge and acting ethically at all times

"The State Engineer was impressed with how thoroughly your data was collected"

— Brennan Engineering



This Dog Has More Tricks

You know WellDog for its award winning gas testing technical services. We now also provide hand-picked exploration and production technologies that can help you address key barriers to successful resource prove-out and monetization, including:

- Reliable, cost-effective continuous downhole pressure/temperature measurement systems
- Unique, proven downhole water/gas separation and re-injection technical services
- Professional, dependable DST/permeability testing services

And we're learning many more tricks, too. Visit welldog.com to see what this old dog can do now!

"We were pleased with the professional manner in which WellDog's field services team conducted the test work"

— Peabody Gas

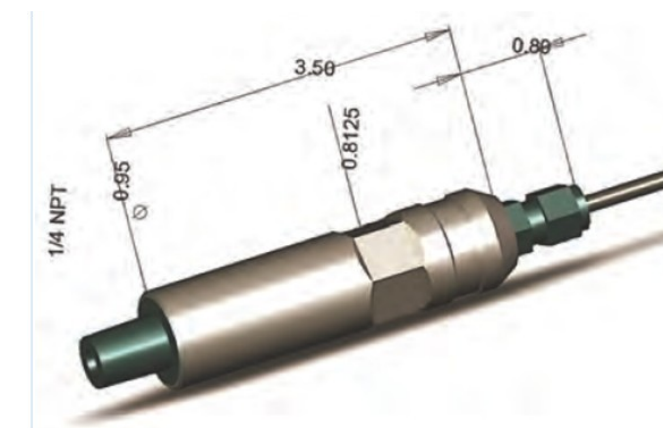

"A significant component of our CBM reservoir analysis since 2006"

— Huber Energy

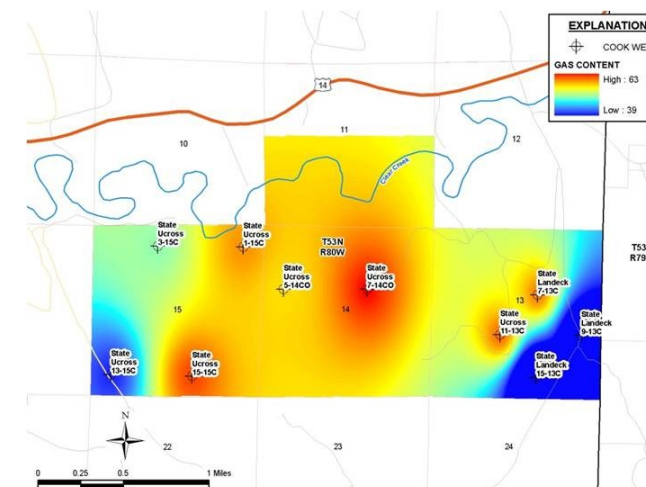

"With this information we were able to make key completion and production decisions for our wells"

— Pinnacle Gas

SINCE 1999

